

**2 HOLE FLANGE MALE RECEPTACLE  
FOR 0.2MM AXIS WITH EMI GASKET**

**R128.481.011**

Series : BMA

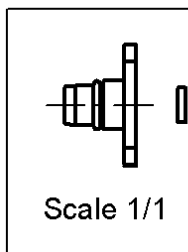
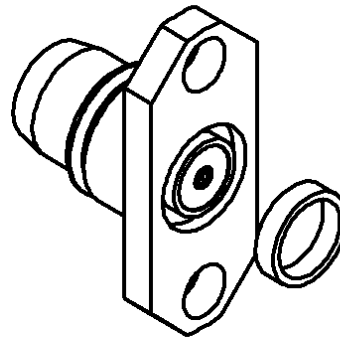
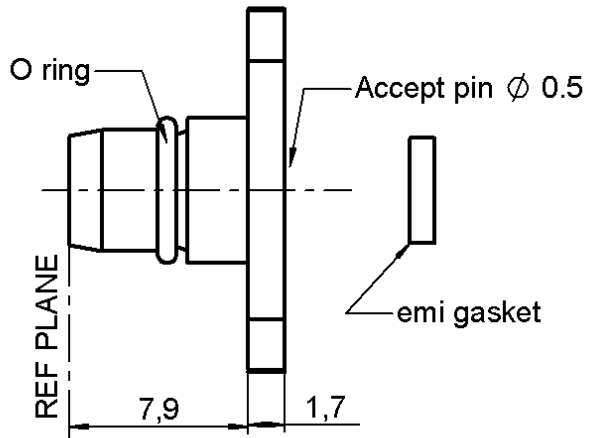
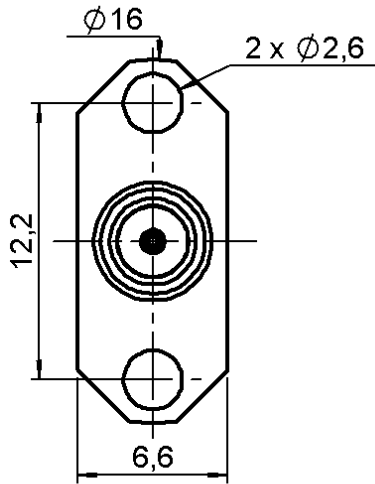

All dimensions are in mm.

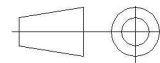

COMPONENTS	MATERIALS	PLATINGS (µm)
BODY	STAINLESS STEEL	PASSIVATED .
CENTER CONTACT	BERYLLIUM COPPER	GOLD 1.3 OVER NICKEL 2
OUTER CONTACT	-	-
INSULATOR	PTFE	-
GASKET	SILICONE CuAg(conductor)	-
OTHERS PARTS	-	-
-	-	-
-	-	-

Issue : 0448 A

In the effort to improve our products, we reserve the right to make changes judged to be necessary.



**2 HOLE FLANGE MALE RECEPTACLE  
FOR 0.2MM AXIS WITH EMI GASKET**

**R128.481.011**

Series : **BMA**

**PACKAGING**

Standard	Unit	Other
<b>1</b>	-	<b>Contact us</b>

**SPECIFICATION**

**ELECTRICAL CHARACTERISTICS**

Impedance		<b>50</b> Ω
Frequency		<b>0-22</b> GHz
VSWR	<b>1.06</b> +	<b>0.010</b> x F(GHz) Maxi
Insertion loss		<b>0.03</b> √F(GHz) dB Maxi
RF leakage	- (	<b>NA</b> - F(GHz)) dB Maxi
Voltage rating		<b>350</b> Veff Maxi
Dielectric withstanding voltage		<b>1000</b> Veff mini
Insulation resistance		<b>5000</b> MΩ mini

**ENVIRONMENTAL**

Operating temperature	<b>-65/+105</b> ° C
Hermetic seal	<b>NA</b> Atm.cm3/s
Panel leakage	<b>NA</b>

**OTHERS CHARACTERISTICS**

Assembly instruction **NA**

Others :  
Mount it with R280.755.000 glass bead  
for hermetic application (see page 3&4)

**MECHANICAL CHARACTERISTICS**

Center contact retention		
Axial force – Mating end	<b>27</b>	N mini
Axial force – Opposite end	<b>27</b>	N mini
Torque	<b>NA</b>	N.cm mini
Recommended torque		
Mating	<b>NA</b>	N.cm
Panel nut	<b>NA</b>	N.cm
Mating life	<b>1000</b>	Cycles mini
Weight	<b>0.000</b>	g

Issue : 0448 A

In the effort to improve our products, we reserve the right to make changes judged to be necessary.



**2 HOLE FLANGE MALE RECEPTACLE  
FOR 0.2MM AXIS WITH EMI GASKET**

**R128.481.011**

Series : BMA

**RECOMMENDED MOUNTING HOLE DETAIL**

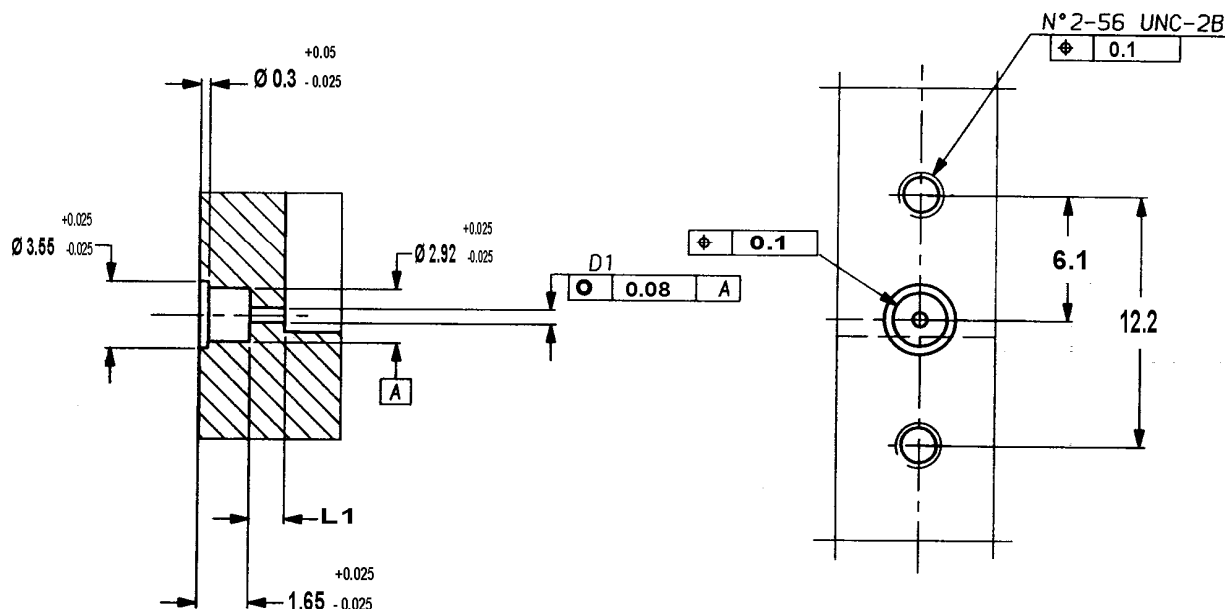

**D1 and L1 dimensions have to be determined according to each application.**

We advise of the two following cases (see page 4)

- using of the the R280.469.010 removable socket :  
D1=2 +/-0.02      L1= 2.5 +/- 0.1
- the glass bead axis is directly welded on the track :  
D1= 1.08 +/-0.02      L1 = from 1 to 4 according to the customer's design criteria

Issue : 0448 A

In the effort to improve our products, we reserve the right to make changes judged to be necessary.



**2 HOLE FLANGE MALE RECEPTACLE  
FOR 0.2MM AXIS WITH EMI GASKET**

**R128.481.011**

Series : BMA

**ASSEMBLY INSTRUCTIONS**

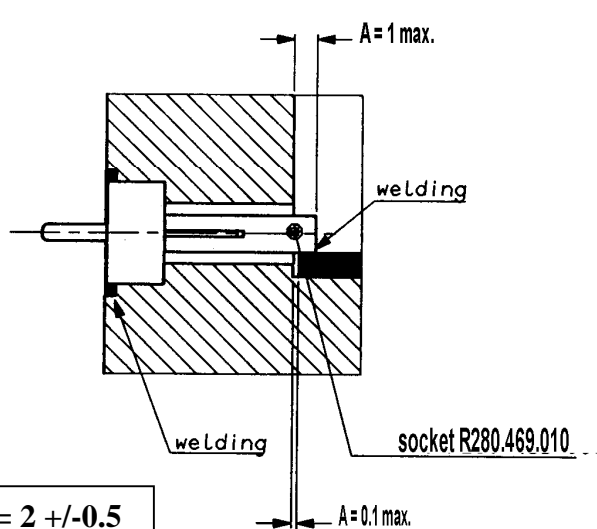
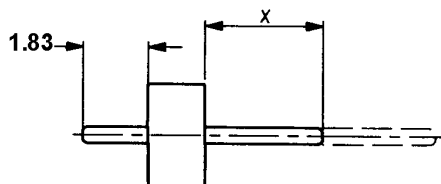

$X = 2 \pm 0.5$

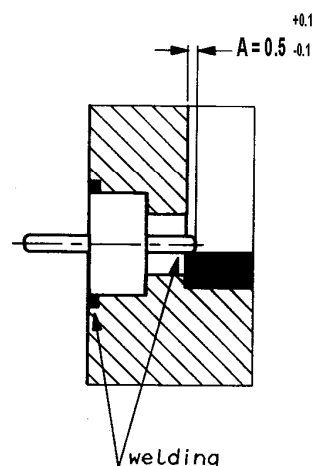

$X = L1 + A$

**GLASS BEAD**

- adjust X by cutting the pin if necessary
- introduce the glass bead into its housing as here above (with the mounted socket)
- weld the ring by putting a welding wire in the groove
- weld the pin (or socket) on the track. Beware of putting too much welding !

**Important :** for maximum RF characteristics the link track/pin must be as thin as possible.

We advise you respect rigorously the dimension A, by welding accurately the bead pin directly on the track (right drawing).

**CONNECTOR**

- set up the « EMI » screening gasket in the connector groove.
- Put the connector on the housing while introducing the bead pin into the socket, then mount the fixtures of the flange.

Issue : 0448 A

In the effort to improve our products, we reserve the right to make changes judged to be necessary.

